

"SAM
JUNIOR

MENU ET JEUX
& GAMES

LE SAM
BISTRO ÉVOLUTIF



Menu "SAM" JUNIOR



Sans gluten
Gluten-free



Sans lactose
Dairy-free



Végétarien
Vegetarian

HORS D'OEUVRES APPETIZERS

Crudités et trempette 🌱 6,50
Raw vegetables with dip

Soupe du jour 🌱 🍷 6,50
Soup of the day

SANDWICHES

1/2 CLUB SANDWICH 13
sur pain traditionnel de blé entier,
servi avec frites maison ou salade mesclun
HALF CLUB SANDWICH
on traditional whole grain bread, served with
homemade French fries or mesclun salad

Hamburger, frites et légumes crus 🌱 15
Hamburger, French fries and raw vegetables
Extra fromage / extra cheese +2,50

PLATS MAIN COURSES

*servis avec frites, légumes crus ou légumes vapeur
*served with French fries, raw or steamed vegetables

POISSON DU JOUR* 20
FISH OF THE DAY*

BŒUF GRILLÉ* 🌱 21
GRILLED BEEF*

POITRINE DE VOLAILLE RÔTIE* 18
ROASTED CHICKEN BREAST *

DOIGTS DE POULET* 10
CHICKEN FINGERS*

PÂTES DU JOUR 14
nature, à la viande,
au fromage ou aux tomates 🌱
PASTA OF THE DAY
plain, meat sauce,
cheese or tomato sauce

PIZZA pepperoni et fromage 14
PIZZA Pepperoni and cheese



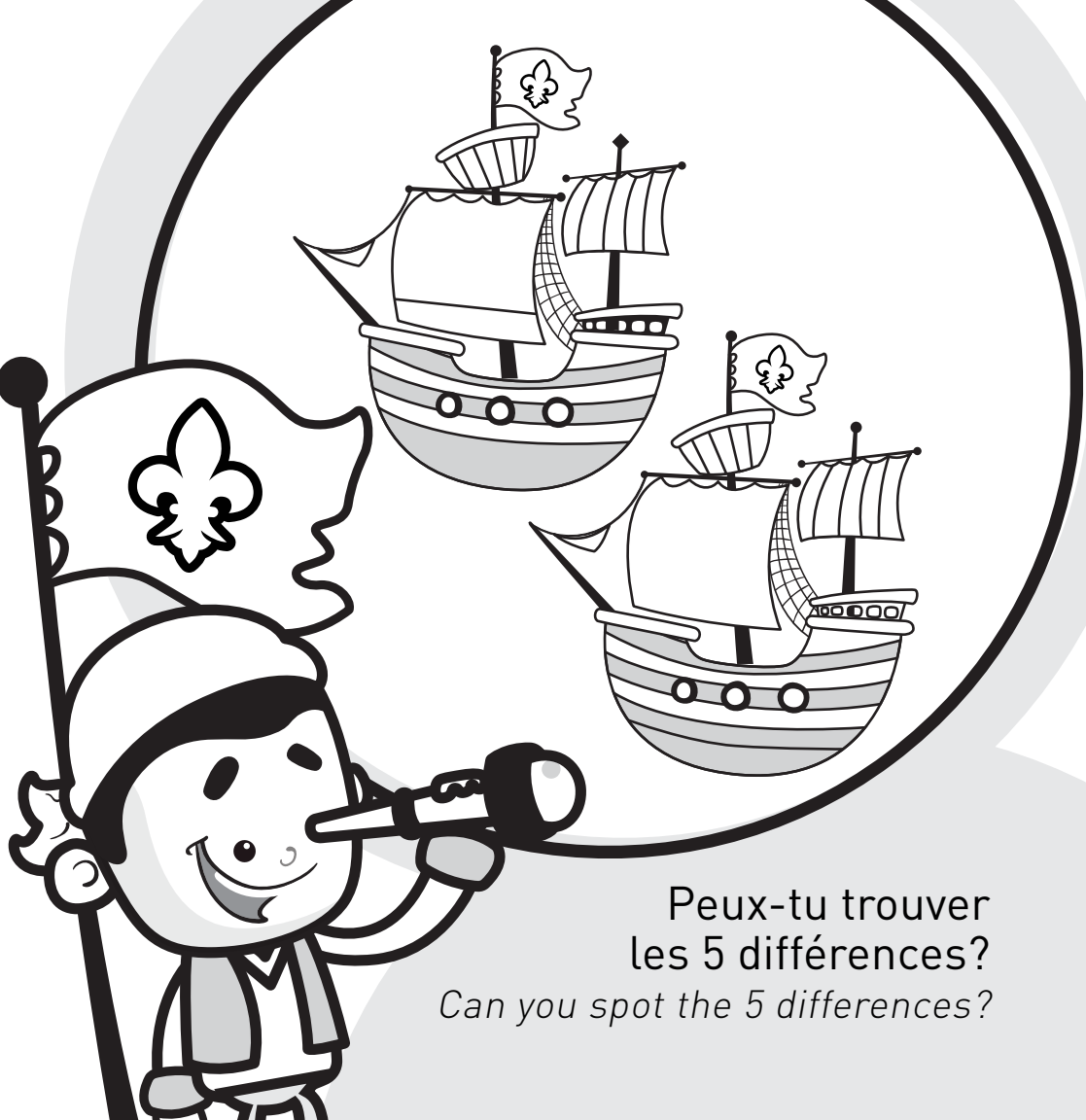

Peux-tu trouver
les 5 différences?
Can you spot the 5 differences?

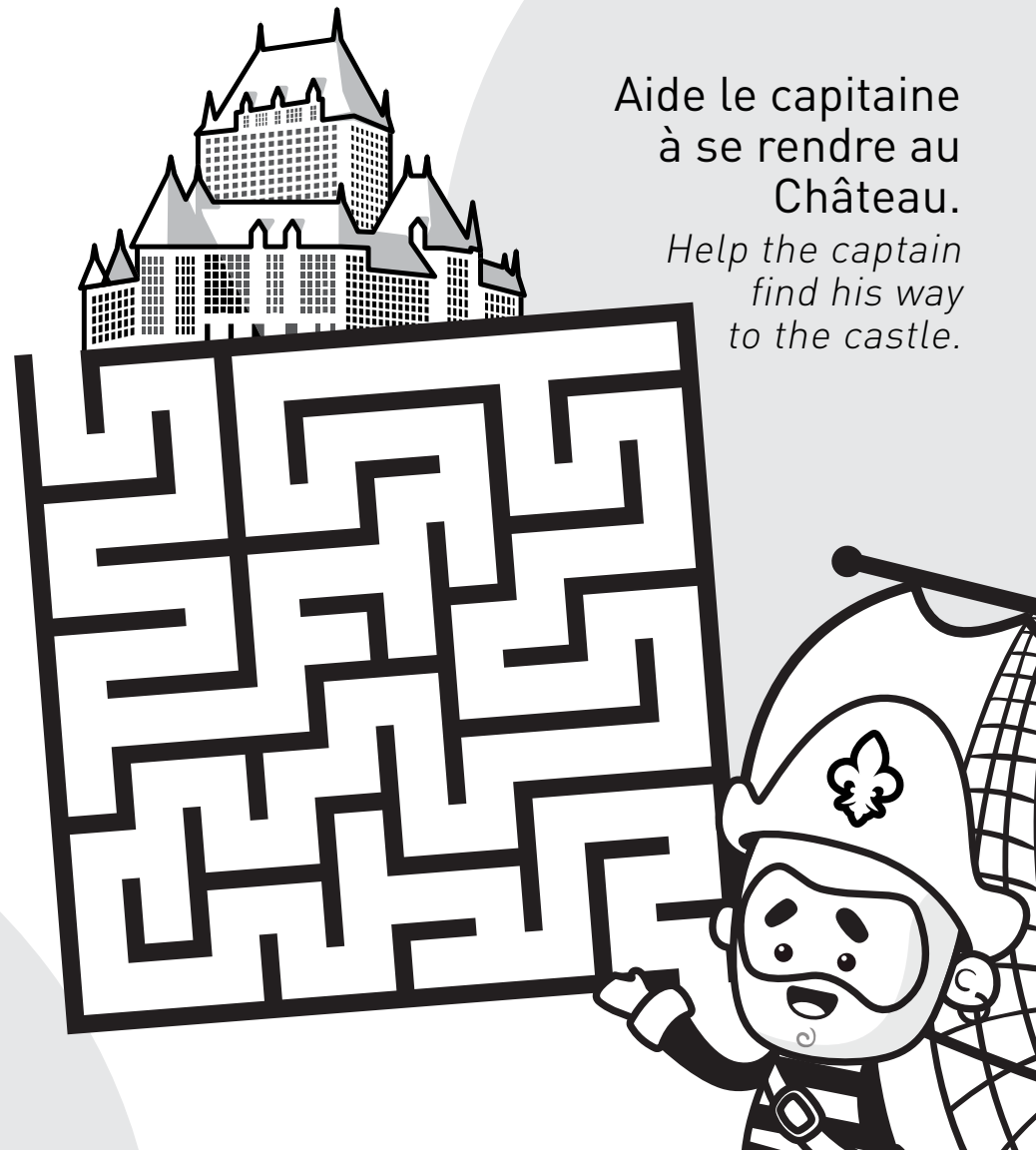

Aide le capitaine
à se rendre au
Château.
*Help the captain
find his way
to the castle.*

Trouve les coordonnées des outils de l'exploratrice.

Find the coordinates of the explorer's tools.

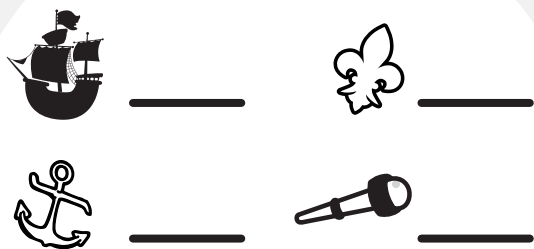
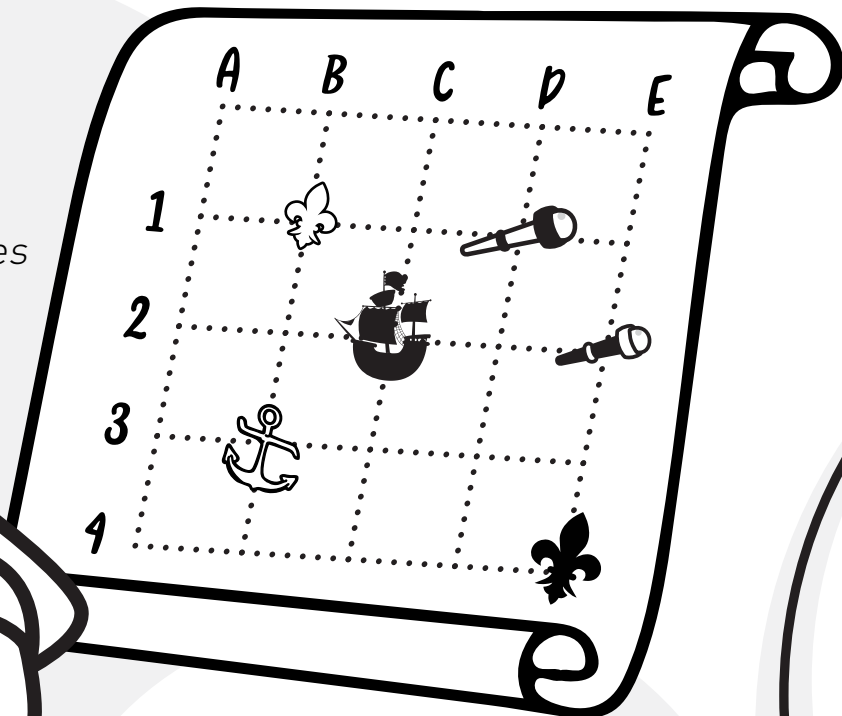

Relie les points et découvre à quoi rêve le matelot.

Connect the dots and find out what the sailor is dreaming about.

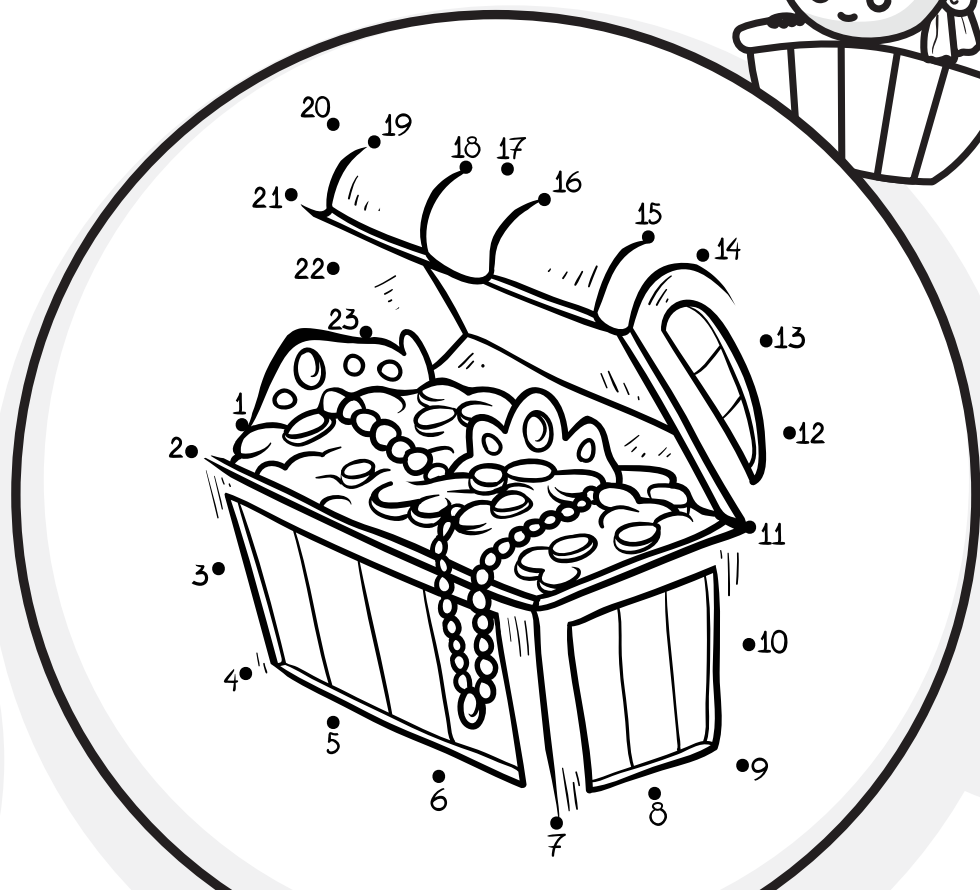

À la
prochaine
See you
soon



LE SAM
BISTRO ÉVOLUTIF